

CASE
CONSTRUCTION

M-SERIES CRAWLER DOZERS

1150M | 1650M | 2050M

SCR
TECHNOLOGY



M-SERIES CRAWLER DOZERS

1150M | 1650M | 2050M

Power and efficiency

SCR only - the only one with SCR: Case Construction is the only manufacturer to offer SCR technology on dozer. With SCR technology, you have exceptional efficiency and fuel saving, full engine power and no losses due to extra cooling needs.

Drawbar pulling leadership: The hydrostatic transmission, and the SCR engine, deliver best-in-class pulling capacity and controllability. All the working parameters can be customized by the driver for excellent machine controllability and faster cycle times.

Productivity boosting electronics: the new cab controls offer a wide choice of electronic settings and automated functions that make the driver's job easier. Together with the lowest noise level in the market, they minimise fatigue on long working days.

Customise your dozer: the M series offers a wider choice of attachments such as blades, rippers, winches or equipment for specific applications such as forestry. You can easily specify the configuration that perfectly meets your needs.

Quick maintenance: the fully openable side panels enable you to service the M series from the ground, while the wide belly plates provide perfect accessibility for extraordinary maintenance.

Telematics: the Site Watch system enables you to monitor your machine's position and performance. Every fleet owner can optimise machine usage and maintenance management for a faster return on investment.





SCR ONLY - THE ONLY ONE WITH SCR

Next generation engine:

The state of the art common rail engine delivers top performance in load response, max torque, power and fuel economy.

The combustion is optimised for maximum efficiency, occurring at high temperatures and using 100% fresh, cool air, as the air intake is separated from the exhaust.

The turbocharged engine with an Air-to-Air intercooler relies on well proven multi injection technology to maximize torque back-up and fuel efficiency with reduced engine noise and vibrations.



10% lower fuel consumption

The SCR engine ensure an optimised engine efficiency. The second generation common rail engine ensures higher injection pressures at all rpm. The electronically controlled injection always matches power to the lowest possible fuel consumption.

The M Series engine can run with 20% biodiesel, reducing even further its environmental impact.



Premium Tier 4 technology: "SCR only"

Case's solution to meet Tier 4 interim emission standards follows two simple steps:

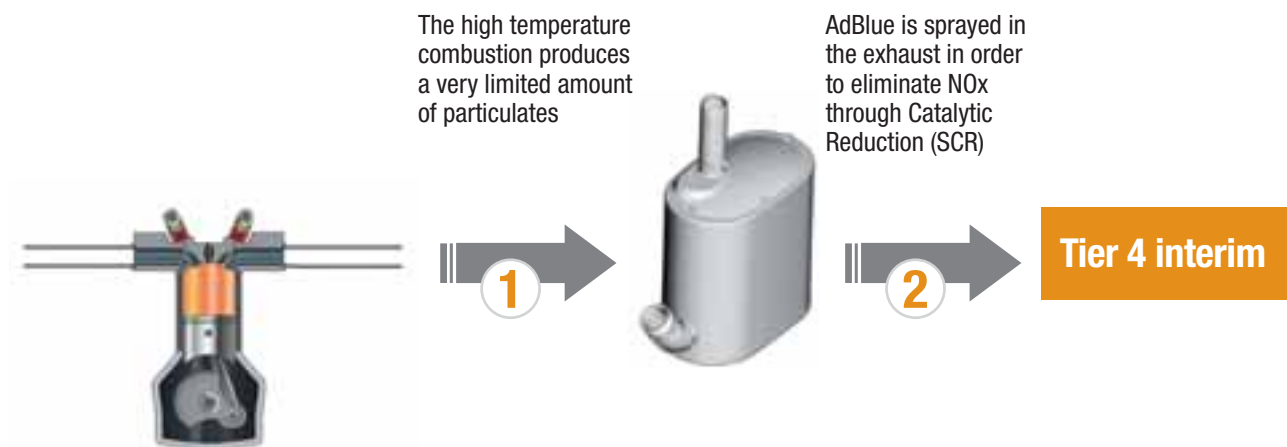

Never ending power

The powerful Case engine ensures high torque back-up under load. When the tractive effort grows and the rpm tends to drop, the engine power grows up to 16% till 1800 rpm. The result: constant performance and higher pulling capacity. In addition, the ability to work with high torque at lower engine rpm reduces engine wear.

DRAWBAR PULLING LEADERSHIP

Dual Path hydrostatic transmission

The entirely re-engineered transmission offers best-in-class pulling capacity combined with the typical manoeuvrability of the hydrostatic solution. The triple reduction final drives ensure high torque on the ground, reducing the working pressure of the entire system and improving its overall efficiency.

“V” shape cooling package

The cooling package of the 1650M and 2050M has been redesigned and fitted with a hydrostatic reversible fan. In the new design, the radiators are mounted with no overlap, so that each radiator receives fresh air, maintaining constant fluid temperatures. The hydrostatic fan continuously adapts its speed to match the real cooling demand, reducing power absorption. The reversing mode reduces maintenance needs and lengthens cleaning intervals.

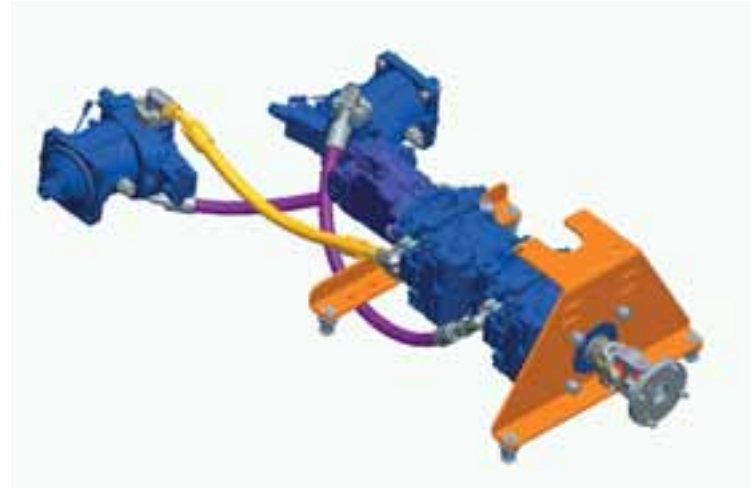

Case extended life tracks

A long life undercarriage can be specified to satisfy the enormous drawbar pulling capacity of the M Series. The exclusive rotating bushing technology of the Case Extended Life Track (CELT) can double the tracks' life, dramatically reducing maintenance costs. In addition, the sprocket is made with 40% more material, extending the life of its teeth. When you consider that maintenance of the undercarriage represents on average 50% of a dozer's maintenance costs, the Case solution brings a clear benefit for the most demanding customers.



PRODUCTIVITY BOOSTING ELECTRONICS



Agile and strong

The operator has full control of the massive power of the M Series dozer. The electrohydraulic joystick enables them to customise the reversing and steering sensitivity for faster and more efficient cycles. The decelerator pedal can be set to either reduce travel speed only or both travel and engine speed.



Automatic blade functions

The advanced electronics functions enable the operator to specific functions in addition to the standard blade movements:

- the on-board computer can be set directly from the joystick;
- the blade reaction can be set choosing from 3 levels of sensitivity;
- the grading button immediately reduces the speed of the blade by 50% for more accurate soil contour;
- the shaking mode enables the operator to shed material quickly, especially when working with sticky soil.



Unmatched visibility

The M series cab is engineered for operator performance, comfort and safety. The new positioning, further forward on the machine, ensures complete blade visibility. The operator can work with confidence and more productively in every operation. The air suspended seat is easy to adjust, providing every operator with a perfect working position. The powerful air conditioning system combined with the best-in-class noise level provide an excellent working environment, reducing operator stress during long working days.

CUSTOMIZE YOUR DOZER



Fully integrated blade control

The M series is ready to work with the most common blade controls available on the market. The machine can be prepared in the factory for a specific configuration, ensuring perfect wire layout, visibility and component integration, guaranteeing the high standards of reliability of every Case product are maintained.



Ready for every task

A wide offering of implements and equipments can be installed on the new CASE dozer:

- Drawbar
- 3 shanks parallel ripper
- Front cab protections and grids
- Winches predisposition

A choice of blades are available for optimum dozing performance:

- PAT
- Foldable PAT (reduces the transport width within 3 m)
- Straight
- Semi-U

All the Bulldozer units offer the patented «Equistatic» system that increases the tilting capability, while reducing the efforts on the pushbeams, increasing the overall frame reliability and reducing the overall wear of components.

QUICK GROUND ACCESS FOR SERVICING





Simple and easy

The hydrostatic transmission brings less complexity and lower maintenance requirements than a traditional one. Belly plates on the bottom of the machine provide excellent access to controls and transmission components. The final drive installation on the main dozer frame enables dismantling while leaving the hydrostatic components in place. The transmission can even be reached through the cab floor, so it can be serviced directly on the jobsite.



Fast refueling

The refueling points (Fuel/Ad Blue/Hydraulic Oil) are conveniently placed on the rear of the cab in a well-protected place. The daily maintenance can be done quickly thanks to dedicated steps that make the access easier and safer.



Ground access for servicing

The new single piece main frame enables you to service the main controls easily from the ground, simply opening the wide lateral shieldings. Oil levels, battery status, electric components, filters and the emergency shut-off switch are rationally grouped and clearly identified with colour coding. With the M Series, you can quickly get ready for your working day.

TELEMATICS



SiteWatch™

The Science Bit

The Case SiteWatch telematics system uses a high-tech control unit mounted on each machine to collate information from that machine and from GPS satellites. This data is then sent wirelessly through the mobile communication networks to the Case Telematics Web Portal.



SiteWatch: Centralised Fleet Control Benefits At Your Fingertips

Measure your true asset availability and optimise it

- Eliminate the “phantom fleet”: SiteWatch allows to identify spare units or under loaded machines on each site.
- Become able to reallocate units where they are more needed.
- Forward Maintenance Planning is easier since the actualised working hours are always available.
- Extend the benefits of SiteWatch to the rest of your fleet: SiteWatch can be installed on the units of other brands as well.

Challenge your Total Cost of Ownership!

- Being able to compare the fuel usage of different machine types will allow you choose the right equipment.
- Save on transport costs with planned and grouped maintenance tasks.
- Peace of mind, optimised uptime and lower repair costs: with preventive maintenance you can for example be alerted if the engine needs to be serviced and avoid a disruptive breakdown.
- Be able to compare your asset Return On Investment on different sites.
- Your equipment is used only during working hours. You can set up alerts so that you know if it is in use during the weekend or at night.
- Integrate with the programmed maintenance package, so that you can be sure every machine is at the right place at the right time.

More Safety, Lower Insurance Premium

- Keep thieves away: dissuade them from attacking your asset because it is geo-localised. SiteWatch is hidden so that thieves can't find it quickly.
- Your fleet is used only where you decide. You can define a virtual fence and receive an email when a machine exits that perimeter.



CRAWLER DOZER

1150M

Specifications

Engine

Model	Case Family 4, F4HFE613Z*A005 Tier 4 Interim
Cylinders	6
Displacement	6.7 l
Fuel injection	Direct
Fuel filter	Spin-on w/ in-line strainer
Air intake	Cross-flow
Cooling	Liquid
Engine speeds	RPM
High idle – no load	2200 +/- 50
Rated – full load	2000
Low idle	800 +/- 25
Horsepower SAE J1349:	
Engine rated net power	127 hp - 95 kW @ 2000 rpm
Engine max net power	138 hp - 103 kW @1800 rpm

Engine lubrication

Pump	Deep sump plate cooler w/ pressurized under-piston nozzles
------	--

Pump operating angle ratings:

Side-to-side	35°
Fore and aft	45°

Radiator:

Core size area	0.26 m ²
Rows of tubes	25

Fan

Diameter	662 mm
Ratio	1.1:1

Powertrain

Dual path hydrostatic

Pump	Variable axial piston
Motor	Variable bent axis piston
Max. drawbar pull*	213.5 kN
Transmission	Single lever control electronic straight tracking
Oil filter	2 micron, spin-on, replaceable
Travel speeds*	
Forward	0 – 9.3 km/h
Reverse	0 – 9.3 km/h
Parking brakes	Heavy-duty, spring-applied, hydraulic pressure release
Steering brakes	Hydrostatic
Final drive	2 helical gear reduction to planetary output
Ratio	61.4:1

Transmission cooling

Type	Oil to air
Core size	0.41m ²

*Measured using standard track chain. Increase travel speeds by 4% and reduce drawbar pull by 4% w/ the optional CELT track chain

Electrical system

Alternator	120 amps
Batteries (2)	12-volt, low-maintenance 925 cold-cranking amps @ -18°C

Operator Environment

ROPS/FOPS cab; Pneumatically suspended seat; Seat belt; Adjustable armrests; Foot rests; Tool storage area; Headliner; Floor mat; Mirror; Noise level 78dba.

Warning lights:

Air filter; Alternator; Diagnostic fault indicator; Engine coolant temperature; Engine oil pressure; Hydraulic filter; Low fuel level; Park brake engaged; Service soon indicator; Transmission filter; Transmission charge pressure.

Gauges:

Ad Blue Level; Battery voltage; Digital hourmeter/tachometer diagnostic/service reminder; Fuel level; Transmission oil temperature; Transmission speed indicator; Water temperature.

Audible warnings:

Engine coolant temperature; Engine oil pressure; Low fuel level, Transmission charge pressure; Transmission/hydraulic temperature; Rear wiper for cab; Internal mirror; Radio.

Hydraulics

Pump flow @ 2200 RPM	140 l/min
Max pressure	206 bar
Lift cylinder™	nr. 2
Bore diameter	108 mm
Rod diameter	50.8 mm
Stroke	488 mm
Angle cylinder	nr. 2
Bore diameter	114.3 mm
Rod diameter	63.5 mm
Stroke	465.7 mm
Tilt cylinder	nr. 1
Bore diameter	127 mm
Rod diameter	63.5 mm
Stroke	148.3 mm

Service Capacity

Fuel tank	322 l
Ad Blue tank	52 l
Engine oil w/ filter	16.4 l
Engine oil w/o filter	15.6 l
Engine cooling system	32.5 l
Hydraulic reservoir	98.4 l
Final drive (per side)	14.2 l
Track rollers (ea)	0.275 l
Front idlers (ea)	0.225 l
Carrier rollers – each	0.334 l

Undercarriage

Track adjustment	Hydraulic
Frame	Oscillating equalizer beam suspension and pivot shaft
Track link pitch	175 mm
Track shoe height	52.5 mm
Pin diameter	36.58 mm

Bushing diameter

CLT track	62 mm
CELT track	79 mm

Track shoes per side

CLT track	43
CELT track	43
Track rollers per side	7
Carrier rollers per side	2
Track roller rail diameter	190 mm

Track on ground

Shoe area	
508 mm	26323 cm ²
559 mm	28965 cm ²
660 mm	34199 cm ²
762 mm	39484 cm ²

Blade

Variable blade pitch	55° +/- 5°
Lift speed – per second	503 mm
Cutting edge	Reversible, replaceable
Width	203.2 mm
Thickness	19.1 mm

Ripper

Max. penetration	478 mm
Width	1711 mm
Cut	1635 mm
Max. ground clearance	424 mm
Max. number of shanks	3
Tooth spacing	
w/3 teeth	785 mm
Hydraulic cylinder	Double-acting
Diameter	102 mm
Stroke	254 mm
Rod	51 mm

Operating Weight

Unit equipped CAB, full fuel tank, 170 lb (77 kg) operator, side shield, track guides, backup alarm, horn, lights and rear retrieval hitch.

	Weight (kg)	Add-on weights	Weight (kg)	CELT chain - per track	Weight (kg)
Long Track	13.809	Drawbar	66	20" (508 mm)	1002
Wide Track	14.807	Ripper (3 shank)	1027	22" (559 mm)	1057
Low Ground Pressure	14.988	Front counterweight	432	26" (660 mm)	1160
				30" (762 mm)	1265
				Center rockguard	134
				Sweeps	63

Track and shoe options

LT (Long Tracks)

508 mm	closed grousers and CLT
508 mm	open grousers and CELT
559 mm	closed grousers and CLT
559 mm	open grousers and CELT

WT (Wide Tracks)

559 mm	closed grousers and CLT
559 mm	open grousers and CELT
660 mm	closed grousers and CLT
660 mm	open grousers and CELT

LGP (Low Ground Pressure)

762 mm	closed grousers and CLT
762 mm	open grousers and CELT

CRAWLER DOZER

1150M

General dimensions

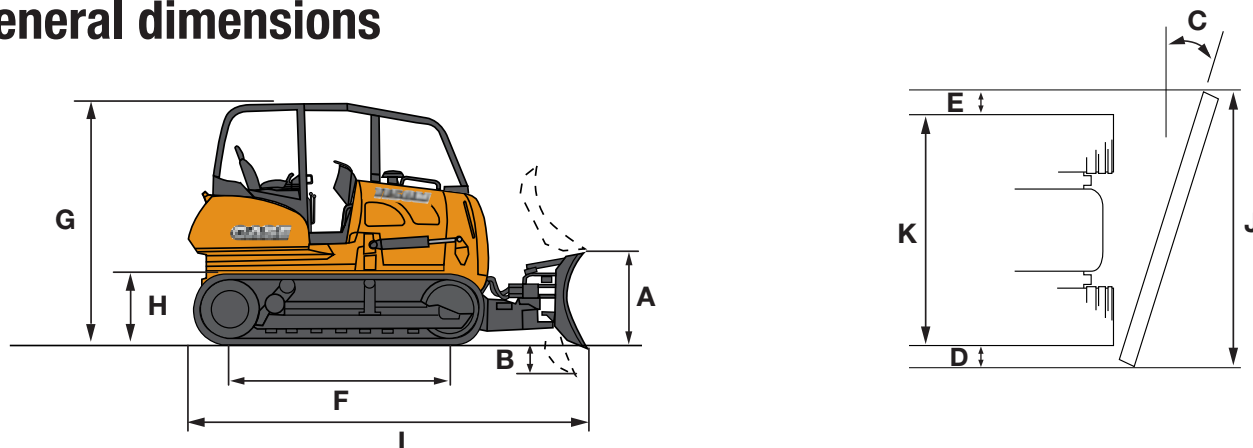

Line drawings are for illustrative purpose only and may not be exact representation of unit.

	LT (Long Track)	WT (Wide Track)	LGP (Low Ground Pressure)
BLADES			
Blade width	3048 mm	3353 mm	3353 mm
SAE blade capacity	2.87 m ³	3.18 m ³	3.18 m ³
A Blade height	1120 mm	1120 mm	1120 mm
Blade lift above ground	956 mm	956 mm	956 mm
B Blade depth below ground	539 mm	590 mm	590 mm
C Blade angle both directions	25°	25°	25°
Blade tilt, each end (up to 8.3°)	430 mm	450 mm	450 mm
D Cast reach	380 mm	370 mm	319 mm
E Cut reach	24 mm	12 mm	63 mm
TRACKS			
Track gauge	1830 mm	2030 mm	2030 mm
Max shoe width	559 mm	660 mm	762 mm
F Track on ground	2590 mm	2590 mm	2590 mm
Area of track on ground	2.90 m ²	3.42 m ²	3.95 m ²
Ground pressure	0.44 kg/cm ² *	0.37 kg/cm ² **	0.32 kg/cm ² ***
DIMENSIONS			
G Height to top of cab	2948 mm	2948 mm	2948 mm
H Ground clearance	330 mm	330 mm	330 mm
I Length			
- Blade straight with drawbar	5080 mm	5080 mm	5080 mm
- Blade straight with ripper	6150 mm	6150 mm	6150 mm
Width			
- Blade straight	3048 mm	3353 mm	3353 mm
J Blade angled	2773 mm	3050 mm	3050 mm
K Over track	2396 mm	2692 mm	2794 mm

*with 559 mm shoes

** with 660 mm shoes

***with 762 mm shoes

NOTE: Ground clearance and overall height dimensions are with the grousers fully penetrated. Add 52.5 mm if unit is on solid surface.



CRAWLER DOZER

1650M

Specifications

Engine

Model _____ Case Family 4, F4HFE613Z*A008 Tier 4 Interim
Cylinders _____ 6
Displacement _____ 6.7 l
Fuel injection _____ Direct common rail
Fuel filter _____ Spin-on w/ in-line strainer
Air intake _____ Cross-flow
Cooling _____ Liquid
Engine speeds _____ RPM
High idle – no load _____ 2200 +/- 50
Rated – full load _____ 2000
Low idle _____ 800 +/- 25
Horsepower SAE J1349:
Engine rated net power _____ 149 hp - 111 kW @ 2000 rpm
Engine max net power _____ 162 hp - 121 kW @1800 rpm

Engine lubrication

Pump _____ Deep sump plate cooler w/ pressurized under-piston nozzles

Pump operating angle ratings:

Side-to-side _____ 35°
Fore and aft _____ 45°

Radiator:

Core size area _____ 0.61 m²
Rows of tubes _____ 4

Fan

Diameter _____ 700 mm
Ratio _____ hydraulically driven

Powertrain

Dual path hydrostatic

Pump _____ Variable axial piston
Motor _____ Variable bent axis piston
Max. drawbar pull* _____ 311 kN
Transmission _____ Single lever control electronic straight tracking
Oil filter _____ 2 micron, spin-on, replaceable
Travel speeds*
Forward _____ 0 – 9.3 km/h
Reverse _____ 0 – 9.3 km/h
Parking brakes _____ Heavy-duty, spring-applied, hydraulic pressure release
Steering brakes _____ Hydrostatic
Final drive _____ 2 helical gear reduction to planetary output
Ratio _____ 61.4:1

Transmission cooling

Type _____ Oil to air
Core size _____ 0.31m²

Electrical system

Alternator _____ 120 amps
Batteries (2) _____ 12-volt, low-maintenance
925 cold-cranking amps @ -18°C

Operator Environment

ROPS/FOPS cab; Pneumatically suspended seat; w/ back adjustment; Seat belt; Adjustable armrests; Foot rests; Tool storage area; Headliner; Floor mat; Tilting seat platform; Noise Level 75 dbA.

Warning lights:

Air filter; Alternator; Diagnostic fault indicator; Engine coolant temperature; Engine oil pressure; Hydraulic filter; Low fuel level; Park brake engaged; Service soon indicator; Transmission filter; Transmission charge pressure.

Gauges:

Battery voltage; Digital hourmeter/tachometer diagnostic/service reminder; Fuel level; Transmission oil temperature; Transmission speed indicator; Water temperature.

Audible warnings:

Engine coolant temperature; Engine oil pressure; Low fuel level, Transmission charge pressure; Transmission/hydraulic temperature.

Hydraulics

Pump flow @ 2200 RPM _____ 160 l/min
Max pressure _____ 248 bar
Lift Cylinder PAT _____ nr. 2
Bore diameter _____ 114.3 mm
Rod diameter _____ 63.5 mm
Stroke _____ 428 mm
Angle cylinder PAT _____ nr. 2
Bore diameter _____ 114 mm
Rod diameter _____ 63.5 mm
Stroke _____ 502.7 mm
Tilt cylinder PAT _____ nr. 1
Bore diameter _____ 127 mm
Rod diameter _____ 63.5 mm
Stroke _____ 148.3 mm
Lift cylinder Bull Dozer
Bore diameter _____ 82.6 mm
Rod diameter _____ 50.8 mm
Stroke _____ 1000 mm
Tilt cylinder Bull Dozer
Bore diameter _____ 114.3 mm
Rod diameter _____ 36.5 mm
Stroke _____ 126 mm

*Measured using standard track chain. Increase travel speeds by 4% and reduce drawbar pull by 4% w/ the optional CELT track chain

Service Capacity

Fuel tank	322 l
AD Blue Tank	52 l
Engine oil w/ filter	16.4 l
Engine oil w/o filter	15.6 l
Engine cooling system	30.2 l
Hydraulic reservoir	160 l
Final drive - per side	14.2 l
Track rollers - each	0.275 l
Front idlers - each	0.225 l
Carrier rollers - each	0.334 l

Undercarriage

Track adjustment	Hydraulic
Frame	Oscillating equalizer beam suspension and pivot shaft

Track link pitch

CLT track	190 mm
CELT track	190 mm
Track shoe height	56 mm
Pin diameter	38 mm

Bushing diameter

CLT track	65 mm
CELT track	86 mm

Track shoes per side

CLT track	45
CELT track	45
Track rollers per side	8
Carrier rollers per side	2
Track roller rail diameter	171.5 mm

Track on ground

Shoe area	
559 mm	34093 cm ²
610 mm	37204 cm ²
711 mm	49524 cm ²
819 mm	37204 cm ²
864 mm	52695 cm ²

Blade

Variable blade pitch - adjustable	55° +/- 5°
Lift speed - per second	483 mm
Cutting edge	Reversible, replaceable
Width	200 mm
Thickness	20 mm

Ripper

Max. penetration	570 mm
Width	1953 mm
Cut width	1889 mm
Max. ground clearance	592 mm
Max. number of shanks	3
Tooth spacing	
w/3 teeth	944 mm
Hydraulic cylinder	Double-acting
Diameter	155 mm
Stroke	596 mm
Rod	69 mm

Operating Weight

Operating weight includes cab, full fuel and hydraulic tanks, 170 lb (77 kg) operator, CLT chain, front pull hook, rear retrieval hitch, track guides, back up alarm, horn, lights, track shoe, C-frame and blade width as noted.

	Weight (kg)	Add-on weights	Weight (kg)	CELT chain - per track	Weight (kg)
Extra Long Track	17899 kg PAT	Drawbar	66	22" (559 mm)	1510
	18806 kg Semi-U	Ripper (3 shank)	1355	24" (610 mm)	1580
Wide Track	18307 kg PAT	Winch	2500	28" (711 mm)	1711
				32" (819 mm)	1801
Low Ground Pressure	18716 kg PAT			34" (864 mm)	1913
				Center rockguard	259
				Sweeps	63

CRAWLER DOZER

1650M

Track and shoe options

XLT (Extra Long Tracks)

559 mm	closed grousers and CLT
559 mm	open grousers and CELT
610 mm	closed grousers and CLT
610 mm	open grousers and CELT

WT (Wide Tracks)

711 mm	closed grousers and CLT
711 mm	open grousers and CELT

LGP (Low Ground Pressure)

819 mm	closed grousers and CLT
819 mm	open grousers and CELT
864 mm	closed grousers and CLT
864 mm	open grousers and CELT

BLADE DIMENSIONS	Bull Dozer Semi-U	Straight PAT	Straight PAT	Foldable PAT
Blade Capacity SAE J1265	4.84 m ³	3.15 m ³	3.15 m ³	3.15 m ³
Undercarriage available	XLT	XLT	WT-LGP	WT - LGP
J Blade width	3322 mm	3302 mm	3974 mm	3974 mm
Blade width in transport position	3322 mm	3000 mm	3608 mm	2887 mm
A Blade height	1319 mm	1180 mm	1000 mm	1000 mm
Max. Tilt	+/- 420 mm	+/- 450 mm	+/- 550 mm	+/- 550 mm
Max. Pitch	+/- 5°	+/- 5°	+/- 5°	+/- 5°
C Max. Angle	-	+/- 28°	+/- 28°	+/- 28°
B Digging depth.	596 mm	539 mm	590 mm	590 mm
Max lift above ground	1133 mm	1130 mm	1130 mm	1130 mm
D Cast reach	468 mm	457 mm	558 mm	584 mm
E Cut reach	468 mm	53 mm	154 mm	80 mm

General dimensions

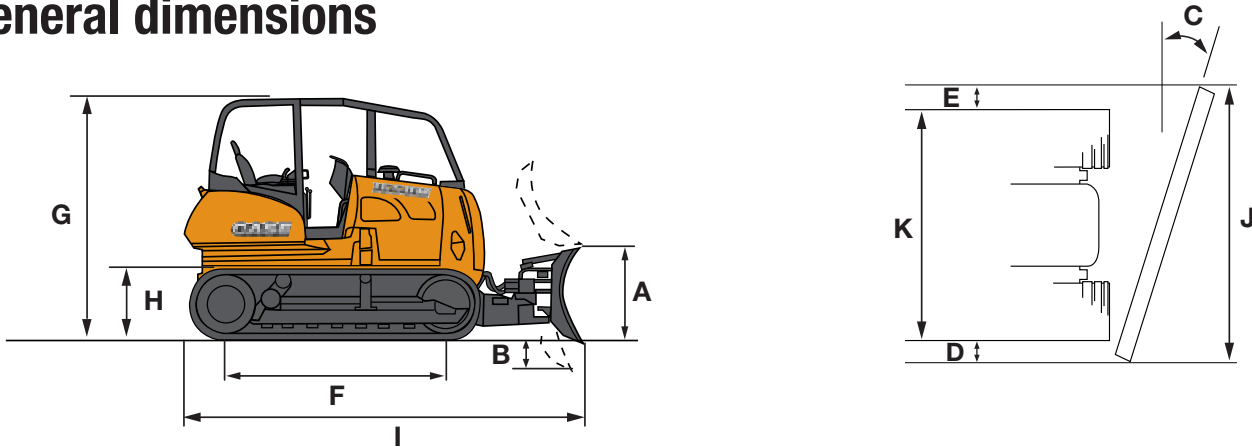

Line drawings are for illustrative purpose only and may not be exact representation of unit.

	XLT (Extra Long Track)	WT (Wide Track)	LGP (Low Ground Pressure)
TRACKS			
Track gauge	1930 mm	2180 mm	2180 mm
Max shoe width	610 mm	711 mm	864 mm
F Track on ground	3050 mm	3050 mm	3050 mm
Area of track on ground	3.72 m ²	4.30 m ²	5.26 m ²
Ground pressure	0.42 kg/cm ² *	0.38 kg/cm ² **	0.31 kg/cm ² ***
DIMENSIONS			
G Height to top of cab	2948 mm	2948 mm	2948 mm
H Ground clearance	321 mm	321 mm	321 mm
I Length			
- Blade straight with drawbar	5678 mm PAT 5928 mm Semi-U	5678 mm	5678 mm
- Blade straight with ripper	6670 mm PAT 6920 mm Semi-U	6670 mm	6670 mm
Width			
- Blade straight	3302 mm PAT 3426 mm Semi-U	3974 mm PAT	3974 mm PAT
J Blade angled	3000 mm PAT	3608 mm PAT 2887 mm PAT Foldable	3608 mm PAT 2887 mm PAT Foldable
K Over track	2489 mm with 559 mm shoes	2895 mm with 711 mm shoes	3044 mm with 864 mm shoes

* with 610 mm shoes and PAT blade
 ** with 711 mm shoes and PAT blade
 *** with 864 mm shoes and PAT blade

NOTE: Ground clearance and overall height dimensions are with the grousers fully penetrated. Add 52.5 mm if unit is on solid surface.

CRAWLER DOZER

2050M

Specifications

Engine

Model _____ Case Family 4, F4HFE613W*A004 Tier 4 Interim
Cylinders _____ 6
Displacement _____ 6.7 l
Fuel injection _____ Direct common rail
Fuel filter _____ Spin-on w/ in-line strainer
Air intake _____ Cross-flow
Cooling _____ Liquid
Engine speeds _____ RPM
High idle – no load _____ 2200 +/- 50
Rated – full load _____ 2000
Low idle _____ 800 +/- 25

Horsepower SAE J1349:

Engine rated net power _____ 214 hp - 160 kW @ 2000 rpm
Engine max net power _____ 232 hp - 173 kW @1800 rpm

Engine lubrication

Pump _____ Deep sump plate cooler w/ pressurized under-piston nozzles

Pump operating angle ratings:

Side-to-side _____ 35°
Fore and aft _____ 45°

Radiator:

Core size area _____ 0.61 m²
Rows of tubes _____ 4

Fan

Diameter _____ 700 mm
Ratio _____ hydraulically driven

Powertrain

Dual path hydrostatic

Pump _____ Variable axial piston
Motor _____ Variable bent axis piston

Max. drawbar pull* _____ 372 kN

Transmission _____ Single lever control electronic straight tracking

Oil filter _____ 2 micron, spin-on, replaceable

Travel speeds*

Forward _____ 0 – 9.3 km/h

Reverse _____ 0 – 9.3 km/h

Parking brakes _____ Heavy-duty, spring-applied, hydraulic pressure release

Steering brakes _____ Hydrostatic

Final drive _____ 2 helical gear reduction to planetary output

Ratio _____ 48.75 :1

Transmission cooling

Type _____ Oil to air
Core size _____ 0.31m²

Electrical system

Alternator _____ 120 amps
Batteries (2) _____ 12-volt, low-maintenance
1200 cold-cranking amps @ -18°C

Operator Environment

ROPS/FOPS cab; Pneumatically suspended seat; w/ back adjustment; Seat belt; Adjustable armrests; Foot rests; Tool storage area; Headliner; Floor mat; Tilting seat platform; Noise level 78dbA.

Warning lights:

Air filter; Alternator; Diagnostic fault indicator; Engine coolant temperature; Engine oil pressure; Hydraulic filter; Low fuel level; Park brake engaged; Service soon indicator; Transmission filter; Transmission charge pressure.

Gauges:

Battery voltage; Digital hourmeter/tachometer diagnostic/service reminder; Fuel level; Transmission oil temperature; Transmission speed indicator; Water temperature.

Audible warnings:

Engine coolant temperature; Engine oil pressure; Low fuel level, Transmission charge pressure; Transmission/hydraulic temperature.

Hydraulics

Pump flow @ 2200 RPM _____ 160 l/min

Max pressure _____ 248 bar

Lift Cylinder PAT _____ nr. 2

Bore diameter _____ 114.3 mm

Rod diameter _____ 63.5 mm

Stroke _____ 428 mm

Angle cylinder PAT _____ nr. 2

Bore diameter _____ 114 mm

Rod diameter _____ 63.5 mm

Stroke _____ 502.7 mm

Tilt cylinder PAT _____ nr. 1

Bore diameter _____ 127 mm

Rod diameter _____ 63.5 mm

Stroke _____ 148.3 mm

Lift cylinder Bull Dozer

Bore diameter _____ 82.6 mm

Rod diameter _____ 50.8 mm

Stroke _____ 1000 mm

Tilt cylinder Bull Dozer

Bore diameter _____ 114.3 mm

Rod diameter _____ 36.5 mm

Stroke _____ 126 mm

*Measured using standard track chain. Increase travel speeds by 4% and reduce drawbar pull by 4% w/ the optional CELT track chain

Service Capacity

Fuel tank	405 l
AD Blue Tank	60 l
Engine oil w/ filter	16.4 l
Engine oil w/o filter	15.6 l
Engine cooling system	30.2 l
Hydraulic reservoir	210 l
Final drive - per side	25 l
Track rollers - each	0.275 l
Front idlers - each	0.225 l
Carrier rollers - each	0.334 l

Undercarriage

Track adjustment	Hydraulic
Frame	Oscillating equalizer beam suspension and pivot shaft

Track link pitch

CLT track	203 mm
CELT track	203 mm
Track shoe height	71.5 mm
Pin diameter	44 mm

Bushing diameter

CLT track	72 mm
CELT track	93 mm

Track shoes per side

CLT/CELT track	40 LT
	45 XLT /WT/LGP

Track rollers per side

LT	7
XLT/WT-LGP	8
Carrier rollers per side	2
Track roller rail diameter	187.5 mm

Operating Weight

Operating weight includes cab, full fuel and hydraulic tanks, 170 lb (77 kg) operator, CLT chain, front pull hook, rear retrieval hitch, track guides, back up alarm, horn, lights, track shoe, C-frame and blade width as noted.

	Weight (kg)	Add-on weights	Weight (kg)	CELT chain - per track	Weight (kg)
Long Track	20213 kg PAT	Drawbar	66	24" (610 mm)	1591
	20206 kg Straight	Ripper (3 shank)	1355	28" (711 mm)	1964
	20485 kg Semi-U	Winch	2500	30" (762 mm)	2009
Extra Long Tracks	20599 kg PAT			36" (914 mm)	2314
	20592 kg Straight			Center rockguard	
	20871 kg Semi-U			LT	221
Wide Tracks	21269 kg PAT			XLT/WT/LGP	306
	21971 kg PAT Foldable			Sweeps	63
	21431 kg Straight				
Low Ground Pressure	22115 kg PAT				
	22790 kg PAT Foldable				
	22123 kg Straight				

Track on ground

Shoe area	
610 mm	32269 cm ² LT
	39979 cm ² XLT
711 mm	45599 cm ² WT
762 mm	49941 cm ² WT
914 mm	59904 cm ² LGP

Blade

Variable blade pitch - adjustable	55° +/- 5°
Lift speed - per second	483 mm
Cutting edge	Reversible, replaceable
Width	200 mm
Thickness	20 mm

Ripper

Max. penetration	570 mm
Width	1953 mm
Cut width	1889 mm
Max. ground clearance	592 mm
Max. number of shanks	3
Tooth spacing	
w/3 teeth	944 mm
Hydraulic cylinder	Double-acting
Diameter	155 mm
Stroke	596 mm
Rod	69 mm

CRAWLER DOZER

2050M

Track and shoe options

LT (Long Tracks)

610 mm	closed grousers and CLT
610 mm	open grousers and CELT

XLT (Extra Long Tracks)

610 mm	closed grousers and CLT
610 mm	open grousers and CELT

WT (Wide Tracks)

711 mm	closed grousers and CLT
711 mm	open grousers and CELT
762 mm	closed grousers and CLT
762 mm	open grousers and CELT

LGP (Low Ground Pressure)

914 mm	closed grousers and CLT
914 mm	open grousers and CELT

BLADE DIMENSIONS	Bull Dozer Straight	Bull Dozer Straight	Bull Dozer Semi-U	Straight PAT	Straight PAT	Foldable PAT
Blade Capacity SAE J1265	3.54 m ³	3.70 m ³	5.58 m ³	4.82 m ³	5.43 m ³	5.43 m ³
Undercarriage available	LT -XLT	WT - LGP	LT-XLT	LT-XLT	WT-LGP	WT - LGP
J Blade width	3334 mm	3901 mm	3426 mm	3606 mm	4064 mm	4064 mm
Blade width in transport position	3334 mm	3901 mm	3426 mm	3287 mm	3690 mm	3023 mm
A Blade height	1128 mm	1110 mm	1420 mm	1310 mm	1318 mm	1318 mm
Max. Tilt	+/- 422 mm	+/- 450 mm	+/- 411 mm	+/- 450 mm	+/- 550 mm	+/- 550 mm
Max. Pitch	+/- 5°	+/- 5°	+/- 5°	+/- 5°	+/- 5°	+/- 5°
C Max. Angle	-	-	-	+/- 28°	+/- 28°	+/- 28°
B Digging depth.	545 mm	539 mm	583 mm	590 mm	590 mm	590 mm
Max lift above ground	1169 mm	1165 mm	1244 mm	1130 mm	1130 mm	1130 mm
D Cast reach	393 mm	363 mm	438 mm	582 mm	472 mm	548 mm
E Cut reach	393 mm	363 mm	438 mm	154 mm	43 mm	119 mm

General dimensions

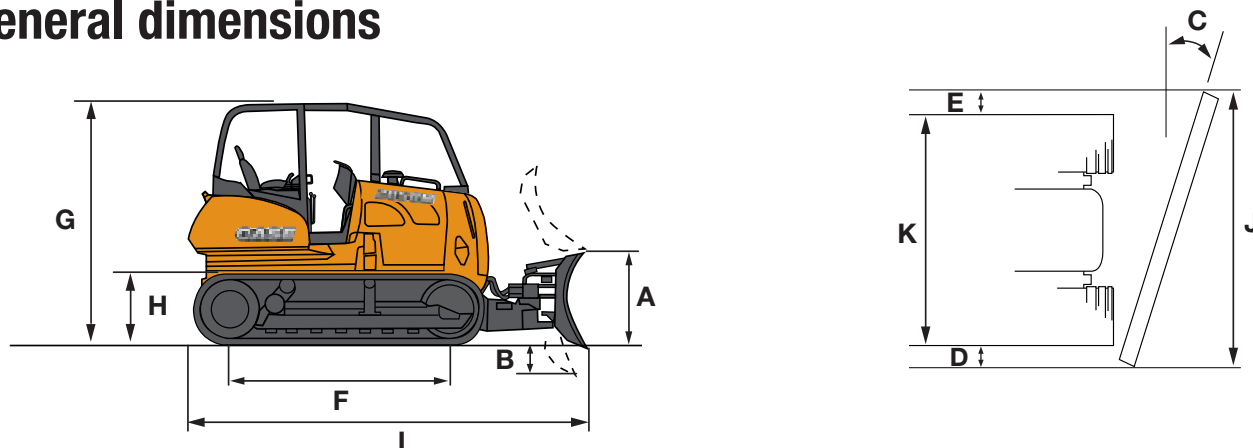

Line drawings are for illustrative purpose only and may not be exact representation of unit.

	LT (Long Track)	XLT (Extra Long Track)	WT (Wide Track)	LGP (Low Ground Pressure)
TRACKS				
Track gauge	1940 mm	1940 mm	2260 mm	2260 mm
Max shoe width	610 mm	711 mm	762 mm	914 mm
F Track on ground	2645 mm	3277 mm	3277 mm	3277 mm
Area of track on ground	3.22 m ²	4.65 m ²	4.99 m ²	5.99 m ²
Ground pressure	0.62 kg/cm ^{2*}	0.44 kg/cm ^{2**}	0.42 kg/cm ^{2***}	0.36 kg/cm ^{2****}
DIMENSIONS				
G Height to top of cab	3103 mm	3103 mm	3103 mm	3103 mm
H Ground clearance	325 mm	325 mm	325 mm	325 mm
I Length				
- Blade straight with drawbar	5491 mm PAT 5387 mm Straight Semi-U	5902 mm PAT 5387 mm Straight Semi-U	5902 mm PAT 5894 mm Straight	5902 mm PAT 5894 mm Straight
- Blade straight with ripper	6974 mm PAT 6869 mm Straight Semi-U	7383 mm PAT 6869 mm Straight Semi-U	7383 mm PAT 6982 mm Straight	7383 mm PAT 6982 mm Straight
Width				
- Blade straight	3606 mm PAT 3334 mm Straight 3426 mm Semi-U	3606 mm PAT 3334 mm Straight 3426 mm Semi-U	4064 mm PAT PAT Foldable 3901 mm Straight	4064 mm PAT PAT Foldable 3901 mm Straight
J Blade angled	3287 mm PAT	3287 mm PAT	3690 mm PAT 3023 mm PAT Foldable	3690 mm PAT 3023 mm PAT Foldable
K Over track	2550 mm with 610 mm shoes	2550 with 610 mm shoes	3022 with 762 mm shoes	3174 with 914 mm shoes

* with 610 mm shoes and PAT blade

** with 711 mm shoes and PAT blade

*** with 762 mm shoes and PAT blade

**** with 914 mm shoes and PAT blade

NOTE: Ground clearance and overall height dimensions are with the grousers fully penetrated. Add 52.5 mm if unit is on solid surface.

Standard Equipment

ENGINE

CASE F4HFE613
Tier 4 Interim Certified
Integral engine oil cooling
Fuel filter
Dual element radial seal air cleaner
120 amp alternator
2 x 12 V batteries
Engine side panels

POWERTRAIN

Dual path infinitely variable, single-lever
Controlled hydrostatic drive, with electronic straight tracking and counter-rotation,
Forward/reverse ratio control,
3 pre-selectable steering sensitivities
3 reversing sensitivities
3 blades sensitivities
Blade Shaking Mode

Fine grading mode
Triple reduction final drive: helical gear/planetary
Decelerator with hydrostatic drive retardation
Automatic spring applied parking brake

UNDERCARRIAGE

Hydraulic track adjusters
Case Lubricated Track Chain
Permanently lubricated track and carrier rollers and idlers
Track adjuster guard
Track guides - front and rear

BLADE

50° - 60° variable pitch with integral adjustment tool
Single lever electro-hydraulic control for blade lift, angle, or tilt
"Equistatic" device for bull dozer version

OPERATOR ENVIRONMENT

Cab:
with heater, A/C, defroster, windshield wiper and lights
Seat belt - 76 mm
Rear wiper for cab
Internal mirror
Radio

OTHER

Backup alarm
Horn
Lights:
2 front
1 rear
Master disconnect switch
Mirror
Rear transmission guard

Options

REAR MOUNTED EQUIPMENT

Ripper - 5 position with 3 shanks
Rear tow hook
Drawbar

SCREENS

Cab rear screen
Radiator brush screen

HYDRAULICS

4 spool hydraulic valve for field-installed ripper
3 spool hydraulic valve without plugs for field-installed ripper
3 spool hydraulic valve with plugs

GUARDS

CAB canopy brush guard
Center rockguard
Sweepbar

BLADES

PAT 3.04 m (1150M)
PAT 3.35 m (1150M)
PAT 3.30 m (1650M XLT)
PAT 3.97 m (1650M WT-LGP)
Foldable PAT 3.97 m (1650 WT-LGP)
PAT 3.60 m (2050M LT-XLT)
PAT 4.06 m (2050M WT-LGP)
Foldable PAT 4.06 m (2050M WT-LGP)
Straight 3.33 m (2050M LT-XLT)

Straight 3.90 m (2050M WT-LGP)
Semi-U 3.42 m (1650M-2050M)

OTHER

Environmental drain
Case Extended Life Track
Grid heater
Additional work lights
Front pull hook
Front counterweight (1150M only)
Blade guidance ready - Trimble
Blade guidance ready - Leica
Blade guidance ready - Topcon
Rearview mirror
Site Watch Telematics tool

Standard and optional equipment shown can vary by country.

Worldwide Case Construction Equipment Contact Information

EUROPE:

via Plava, 80
10135 TORINO - ITALIA

AFRICA/MIDDLE EAST/CIS:

Riva Paradiso 14
6902 Paradiso - SWITZERLAND

NORTH AMERICA/MEXICO:

700 State Street
Racine, WI 53404 U.S.A.

LATIN AMERICA:

Av. General David Sarnoff 2237
32210 - 900 Contagem - MG
Belo Horizonte BRAZIL

ASIA PACIFIC:

Unit 1 - 1 Foundation Place - Prospect
New South Wales - 2148 AUSTRALIA

CHINA:

No. 29, Industrial Premises, No. 376.
De Bao Road, Waigaoqiao Ftz, Pudong,
SHANGHAI, 200131, P.R.C.

CASE Construction Equipment

CNH UK Ltd
Unit 4,
Hayfield Lane Business Park,
Field Lane, Auckland,
Doncaster,
DN9 3FL
Tel. 00800-2273-7373
Fax +44 1302 802829

CASE Customer Assistance
00800-2273-7373

The call is free from a land line. Check in advance with your Mobile Operator if you will be charged.



NOTE: Standard and optional fittings can vary according to the demands and specific regulations of each country. The illustrations may include optional rather than standard fittings - consult your Case dealer. Furthermore, CNH reserves the right to modify machine specifications without incurring any obligation relating to such changes.

Conforms to directive 2006/42/EC

